

SERIE 77

HOLLOW SHAFT INCREMENTAL ENCODER FOR INDUSTRIAL APPLICATIONS

- Resolution up to 5.000 pulses per turn
- External diameter 77 mm
- Hollow shaft from 15 to 25 mm
- Protection class IP65 according to DIN 40050
- Connection by cable (any cable length available) or industrial connector.
- Fixed to shaft with front or rear setscrews
- Anti-rotation system using elastic flange



Front screws

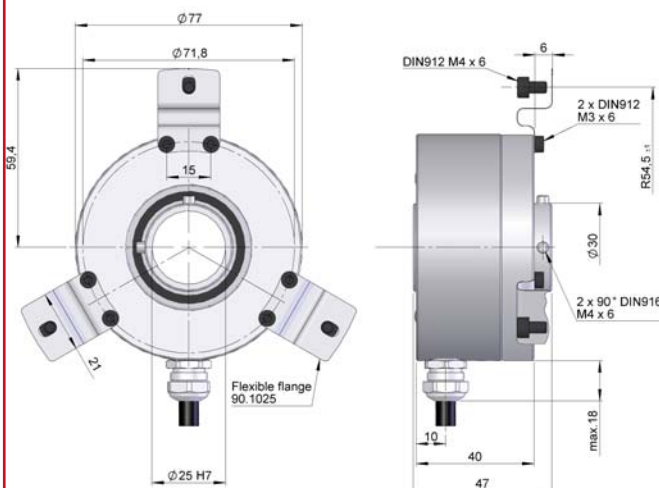

Rear screws

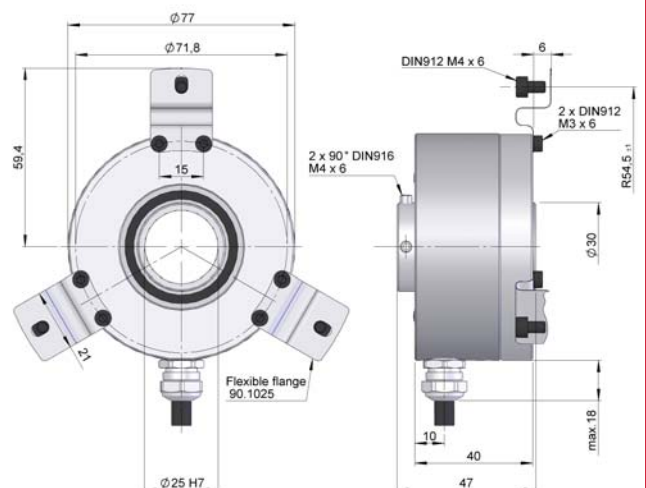

Previous mounting and installation of the encoder is recommended to read the section "TECHNICAL CONSIDERATIONS".

MECHANICAL SPECIFICATIONS

Housing	Aluminium.
Shaft	Aluminium (optional, stainless Steel).
Bearings	Ballraces.
Bearings lifetime	1x10 ¹⁰ rev.
Housing fixation	Elastic flange 90.1025.
Shaft fixation	Front or Rear clamp.
Hollow shaft diameter	15..25 mm.
Maximum number of revolutions permitted mechanically	6000 rpm.
Protection against dust and splashes according to DIN 40050	IP65.
Rotor inertia moment	Max. 1 Kg cm ² .
Starting torque at 20°C (68°F) ,	Max. 4 Ncm.
Maximum load permitted on axial shaft	100 N.
Maximum load permitted on radial shaft	200 N.
Permitted misalignment: Elastic flange 90.1025 (one)	±0.5 mm axial, ±0.3 mm radial.
Elastic flange 90.1025 (three)	±0.4 mm axial, ±0.2 mm radial.
Weight aprox.	0,5 Kg.
Operating temperature range	-20°C to +80°C.
Vibration	100 m/s ² (10Hz...2000Hz).
Shock	1000 m/s ² (6ms).
Maximum pulses per turn	5.000
Radial connection	Cable 2 metres or industrial connector (other cable lengths available on order).

ELECTRICAL SPECIFICATIONS

OUTPUT SIGNALS

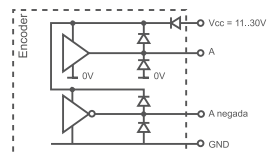
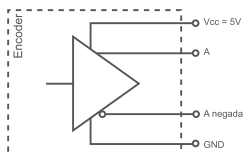

	RS422 (TTL compatible)	Push-Pull Differential
Power supply	5 V ±5%	11...30 V
Consumption	Typical: 70 mA Max: 150 mA	Typical: 45 mA Max: 150 mA
Max. load capability	±20 mA	±30 mA
Length of cable allowed	1200 m	100 m
"Low" signal level	$V_{OL} < 0,5 V$	$V_{OL} < 2.5 V$
"High" signal level	$V_{OH} > 2.5 V$	$V_{OH} > V_{cc} - 3 V$
Frequency	300 kHz	200 kHz
Short circuit protection	Yes	Yes
Protection against polarity inversion	No	Yes
Channel B leads (90° electric) channel A		

CONNECTION



	Cable 3x2x0,14+2x0,34	90.9512 M23 12p
GND	Black	1
Vcc	Red	2
A	Yellow	3
B	Green	4
A inverted	Brown	5
B inverted	Blue	6
0 (reference)	Grey	7
0 inverted	Orange	8

ORDERING CODE

SERIE	FIXATION	HOLLOW SHAFT	OUTPUT SIGNALS	CONNECTION	ELECTRONIC OUTPUT	PULSES NUMBER	SPECIAL CUSTOMER
77	● ↓ 1- Rear setscrews 2- Front setscrews	● 15- Ø15 mm 16- Ø16 mm 18- Ø18 mm 20- Ø20 mm 24- Ø24 mm 25- Ø25 mm	● ● 1- A \bar{A} + B \bar{B} + 0 $\bar{0}$ 2- A \bar{A} + B \bar{B}	● 1- Radial cable 2- Radial 90.9512	● ↓ 1- Differential line driver. Push-Pull 11..30V 2- Standard RS422. 5V	● ● ● ● ●	● ● ● ● ●

ACCESSORIES

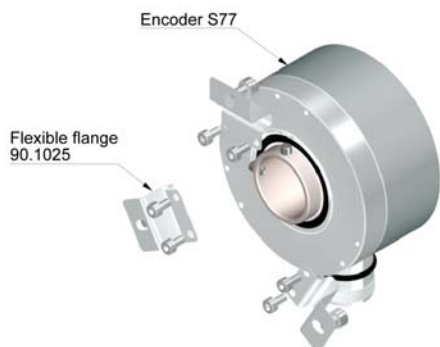

All the accessories available in the sections "SIGNAL CONDITIONERS" and "MOUNTING ACCESSORIES".