

SPP-94

- ▣ flow meter, batcher, totalizer
- ▣ 1 input 0/4-20 mA
- ▣ 1 programmable function input
- ▣ 2 or 4 relay (or OC) outputs
- ▣ option: active current output
- ▣ RS-485 / Modbus RTU



SPP-94 are the flow meters designed to work in tandem with the pulse flow transducers with current input of 0-20 mA or 4-20 mA. Wide range of total flow (up to 16 significant digits) enables flow volume control for a long time. Build in a batcher function makes possible application of SPP-94 in a wide range of industry branches (food production, pharmacy, paint and varnish). The counters have 2 or 4 relay (or OC) outputs, depending on the actual instantaneous, batcher or total values of the flow (only R1 output).

- display of instantaneous and the total flow values,
- batching and counting of doses,
- setting the volume units, the flow time and decimal point,
- settable delay time of control outputs: up to 99 sec. or min. and threshold hysteresis setting,
- ACCESS option - easy threshold modification.

Typical applications

Filling a tank with the flow rate measurement and alarm signalling.

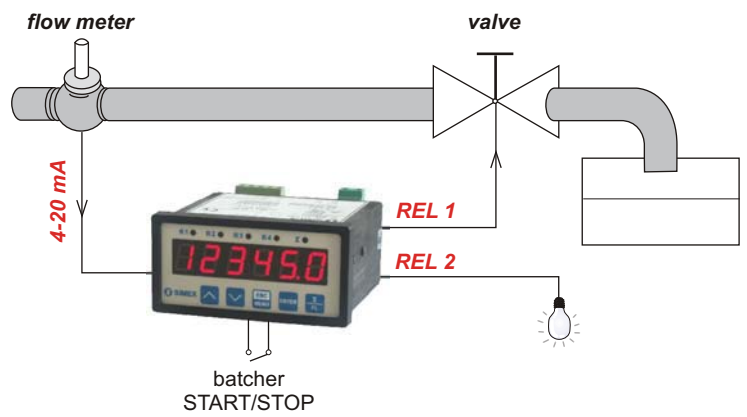

Exemplary pin assignment

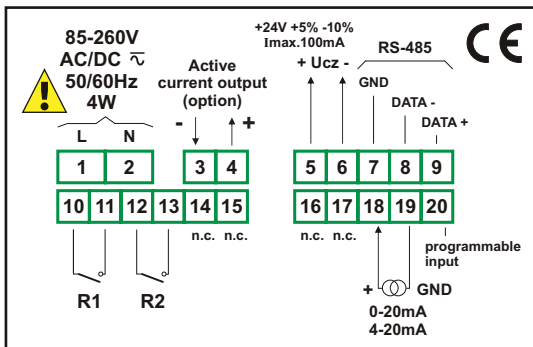

version with 4-20 mA output and two relays

Technical data

- Power supply:** 19V + 50V DC; 16V + 35V AC or 85 + 260V AC/DC, all separated
- Power consumption:** for 85 + 260V AC/DC and 16V + 35V AC power supply: max. 4,5 VA; 19V + 50V DC power supply: max. 4,5 W
- Display:** LED, 6 x 13 mm high, red (green - on request)
- Inputs:** measurement
 - current 0-20 mA or 4-20 mA, overload-protected, sinking current limited to about 40 mA
 - programmable
 - binary 24V DC, not separated
- Displayed values range:** 0 + 999999 + decimal point
- Current measurement accuracy:** 0.1% @25°C (for 0+20 mA range)
- Stability:** 50 ppm/°C
- Accepted prolonged input overload:** 20%
- Resistance of measuring input:** < 65 Ω (typical 55 Ω)
- Totalizer counter capacity:** over 4 x 10⁹ m³ with max. resistance 0,001 l
- Total flow and batcher counter precision:** selected from range: 0 + 0.000
- Batcher counter range:** 65536 m³
- Outputs:** 2 or 4; relays 1A/250V AC (cosφ=1) or the OC 30mA/30VDC/100mW
- Transducer power supply output:** 24V DC +5%, -10% / max. 100 mA, stabilized, not insulated from measuring inputs
- Active current output:** operating range max. 0 - 24 mA, load resistance max. 700 Ω (option available with 2 relays, see ordering)
- Communication interface:** RS-485, 8N1 and 8N2, 1200 bit/s + 115200 bit/s, Modbus RTU (not galvanically insulated)
- Data memory:** non-volatile memory, EEPROM type
- Operating temperature:** 0°C + +50°C
- Storage temperature:** -10°C + +70°C
- Protection class:** IP 65 (front), available additional frame IP 65 for panel cut-out sealing; IP 20 (case and connection clips)
- Case:** board
- Case material:** NORYL - GFN2S E1
- Case dimensions:** 96 x 48 x 100 mm
- Panel cut-out dimensions:** 90,5 x 43 mm
- Installation depth:** min. 102 mm
- Board thickness:** max. 5 mm

Ordering

- SPP-94-11XX-1-X-XX1**
- options:**
 - 00 : no options
 - 01 : IP 65 frame
 - power supply:**
 - 3 : 24V AC/DC
 - 4 : 85V - 260V AC/DC
 - number of outputs:**
 - 1 : REL (for 2 and 4 outputs)
 - 2 : OC (for 2 and 4 outputs)
 - 3 : 2 x REL + current output
 - 4 : 2 x OC + current output
 - type of outputs:**
 - 1 : REL (for 2 and 4 outputs)
 - 2 : OC (for 2 and 4 outputs)
 - 3 : 2 x REL + current output
 - 4 : 2 x OC + current output