

DUCT SMOKE DETECTOR KRM-X-2

KRM-X-2 duct smoke detector is designed for smoke detection in ventilation ducts. The detector is a combination of a smoke detector and an adapter system. The adapter system has been specially designed for optimal air flow through the smoke detector. The air duct sensor measuring tube transports the air through the sensing chamber and back into the air duct. Measuring tube is designed to detect smoke at very low flow rates.

KRM-X-2 sensor smoke detection is based on light scattering. The device housing includes a RM3.3-X / ALN-E type smoke alarm as well as flow monitoring, electronics, terminals and user interface. KRM-X-2 reacts immediately to smoke and triggers an alarm. Over time, the sensor becomes contaminated. Because of alarm threshold tracking, the sensitivity up to total pollution remains the same. The contamination level is indicated in a two-digit LED display. KRM-X-2-MOD and KRM-X-2-BAC models are equipped with bus interface RS-485.

KRM-X-2 can be mounted directly to a rectangular and uninsulated ventilation duct. To mount the detector to round or insulated duct, a special fitting plate is needed.

The product is equipped with 160 mm measuring tube which is normally enough for most applications. Longer tubes are also available.

Wiring

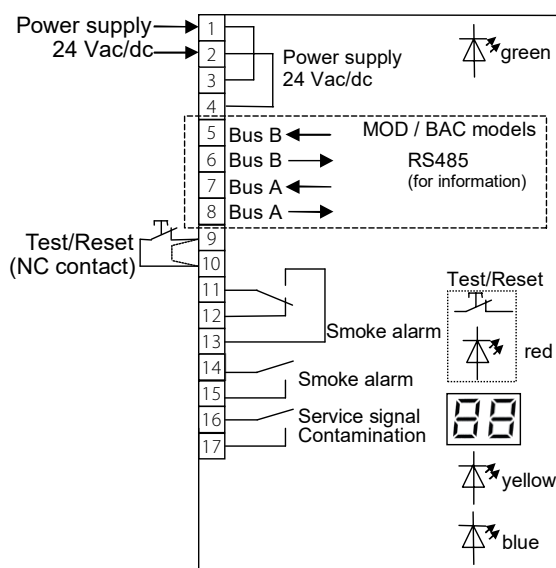

Technical data

Supply	24 Vac (16...27,6 V) or 24 Vdc (21,6...27,6 V)
Sensor	Optical RM3.3-X (ALN-E)
Rated current	max. 120 mA
Relay outputs	floating
Alarm relay	1 changeover contact, 8 A, 250 Vac or 24 Vdc. 1 NC, 8 A, 250 Vac or 24 Vdc.
Contamination relay	NC contact, 6 A, 250 Vac or 24 Vdc
Operating conditions	
temperature	-20...50 °C
humidity	10...95 % non-condensing
air flow	1...20 m/s
Housing	IP65, ABS
Air measuring tube	Aluminium / plastic, length 160 mm
Dimensions (w x h x d)	172 x 271 x 85 mm
Cable glands	3 x M16
Approvals	VdS approval (G219046, G219053, DIN EN 54-27)

Ordering guide:

Model	Product number	Description
KRM-X-2-0,16	1137060	duct smoke detector
KRM-X -2-MOD	1137070	Modbus duct smoke detector
KRM-X -2-BAC	1137080	BACnet duct smoke detector
KS-X	1137093	mounting plate for round or insulated ducts
WDG-X	1137094	protective insulating housing with alarm display for outdoor installation
KS-WDG-X	1137095	mounting plate for round or insulated ducts (with WDG-X)
ASR-A10	1137096	test gas
KRM-RM3.3-X	1137097	smoke sensor

Products fulfil the requirements of directive 2014/30/EU and are in accordance with the standards EN61000-6-3 (Emission) and EN61000-6-2 (Immunity).